

Pneumatically operated 2/2 way diaphragm valve with stainless steel actuator



- Flow optimized and deadleg free stainless steel cast or forged bodies
- Media separation with different diaphragm materials
- Trusted inner parts for long cycle life
- Actuator in stainless steel for demanding environments
- Large accessory program with stroke limitation and feedback

Type 2063 can be combined with...



Type 2103

Diaphragm valve



Type 2031

Diaphragm valve



Type 8697

Feedback unit

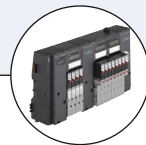

Type 8647

AirLINE SP

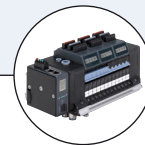

Type 8652



AirLINE

The pneumatically operated diaphragm valve with stainless steel actuators fulfils the demands of tough process environments. Forged or casted bodies in high quality stainless steel have excellent cleanability and surface qualities that are required in pharma, biopharma, cosmetic or food and beverage industry. The stainless steel actuator is designed to withstand tough process environments. Laser welding allows a design without seals and smooth surfaces that is both cleanable and robust. With a ducted exhaust air port the actuator can be isolated from the environment an optimum from a lifetime and hygienic point of view. The trusted diaphragm materials are optimized for a long cycle life and comply to USP Class IV, FDA and EC-Regulation 1935/2004. Placed within the Bürkert diaphragm valve program various port connections, and a large accessory program are available, also explosion proof variants.

Technical data	
Port connection	DN15 to 50
Body material Forged version Cast version	Forged stainless steel 316L/1.4435/BN2 Cast stainless steel 316L /1.4435
Port connections Welded acc. to Clamp and threaded	EN ISO 1127/ISO 4200, DIN 11866 RB, DIN 11850 R2, DIN 11866 RA, DIN EN 10357 RB, ASME BPE, DIN 11866 RC on request: SMS 3008, BS 4825 on request
Actuator material Cover Diaphragm cover	1.4404 (316L) 1.4308
Diaphragm materials	EPDM (AD), PTFE/EPDM (EA), advanced PTFE/EPDM (EU), GYLON®/EPDM laminated (ER) on request
Medium	Neutral gases and liquids, high purity, sterile, aggressive or abrasive fluids
Viscosity	up to viscous
Surface finishes - forged version internal mechanically polished (with external forged surface) internal electropolished (with external forged surface electropolished)	(average surface finish) Ra ≤ 0.5 µm (ASME BPE SF1) on request Ra ≤ 0.38 µm (ASME BPE SF4)
Surface finishes – cast version internal mechanically polished (with external cast surface) internal electropolished (with external cast surface electropolished)	(average surface finish) Ra ≤ 0.76 µm (ASME BPE SF3) Ra ≤ 0.6 µm (ASME BPE SF6) on request

Tube formed body on request

Content

Valve specifications		System spec. On/Off		Request for quotation	
	Type 2063 On/Off		Type 8801-DV	Type 8801-DV	p. 13-15
Technical data & Ordering charts	p. 1-9	Ordering infos & Ordering charts	p. 11-14		
Forged version	p. 4-6				
Cast version	p. 7-10				
Dimensions	p. 10				

Technical data, *continued*

Technical data, continued	
Medium temperature	
EPDM (AD)	- 10 to +143 °C (steam sterilisation +150 °C for 60 min)
PTFE/EPDM (EA)	- 10 to +130 °C (steam sterilisation +140 °C for 60 min)
PTFE/EPDM (EU)	- 5 to +143 °C (steam sterilisation +150 °C for 60 min)
GYLON®/EPDM laminated (ER)	- 5 to +130 °C (steam sterilisation +140 °C for 60 min)
Ambient temperature	0 °C to +60 °C, autoclavable
Control medium	Neutral gases, air
Max. pilot pressure	max. 10.5 bar* * with actuator size 130 mm (P) max. 7.5 bar
Pilot air ports	Thread G 1/8
Installation	as required, preferably with actuator in upright position

Technical data valves

Pressure values

Diaphragm size	Actuator size Ø [mm]	Permitted pilot pressure [bar]		Max. operating pressure [bar] for seal material	
		min.	max.	EPDM	PTFE/EPDM advanced PTFE/EPDM, GYLON®/EPDM laminated
15	50 (D)	5	10.5	8.5	5
	70 (M)			10	10
20	70 (M)	5	10.5	10	10
	70 (M)			6.5	4.5
25	90 (N)	5.5	10.5	10	8
	90 (N)	5.5	10.5	8	6
40	90 (N)	5.5	10.5	5.5	5
	130 (P)	5	7.5	10	10
50	130 (P)	5	7.5	8	7

Pressure valves [bar]: Overpressure to the atmospheric pressure

Installation for self-draining operation

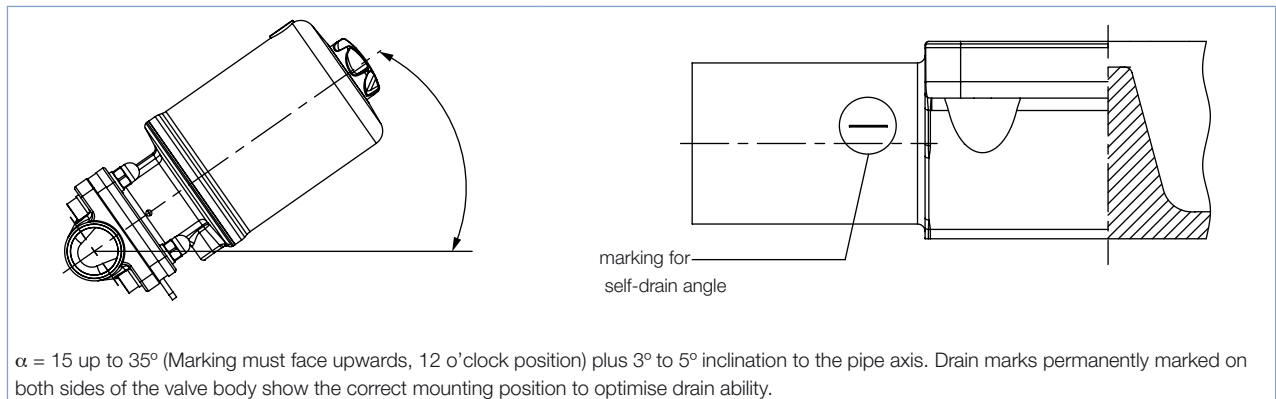

Approvals

Suitability for foodstuffs / sterile applications



- The composition of the, EPDM (AD), PTFE/EPDM (EA), advanced PTFE (EU) and GYLON®/EPDM laminated (ER) diaphragms corresponds to the Code of Federal Regulations, published by the FDA (Food and Drug Administration, USA).



- The composition of the, EPDM (AD), PTFE/EPDM (EA), advanced PTFE (EU) and GYLON®/EPDM laminated (ER) diaphragms is suitable for the application with food and beverage (acc. to EC-Regulation 1935/2004/EC)
- The composition of the, EPDM (AD), PTFE/EPDM (EA), advanced PTFE (EU) and GYLON®/EPDM laminated (ER) diaphragms are approved acc. USP Class VI.

Materials Type 2063 Diaphragm valve

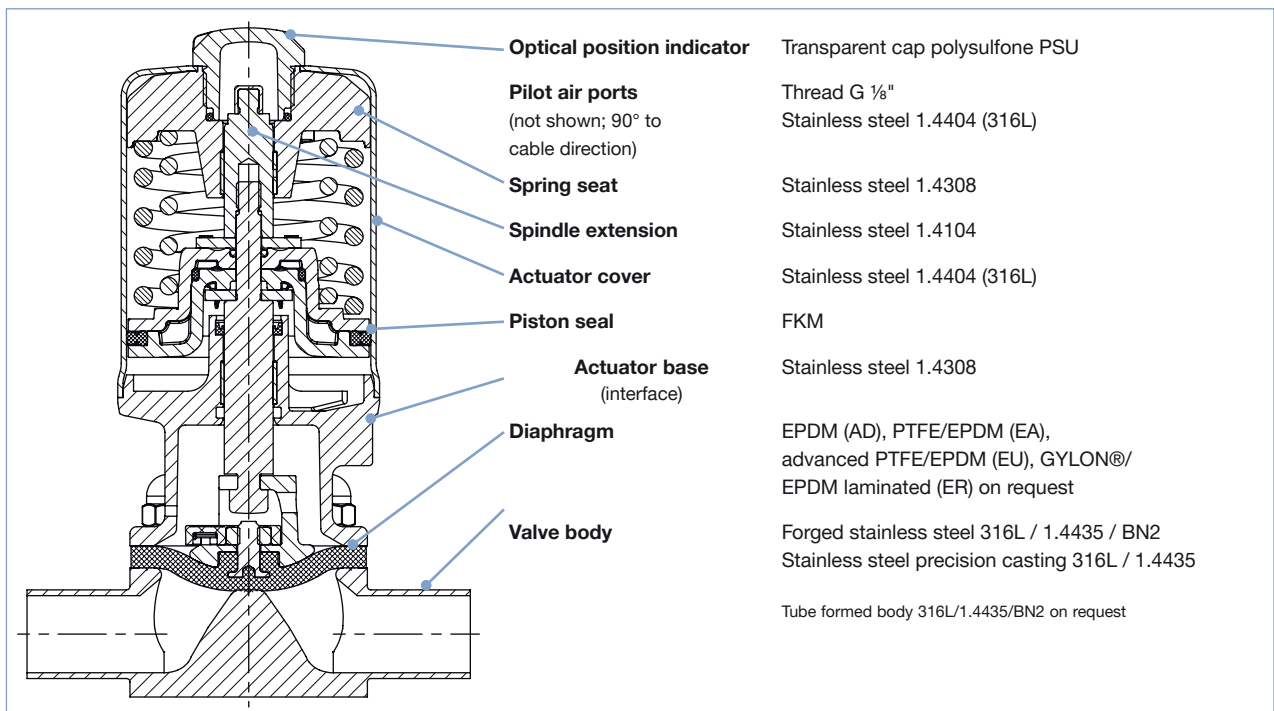

Forged

Body label

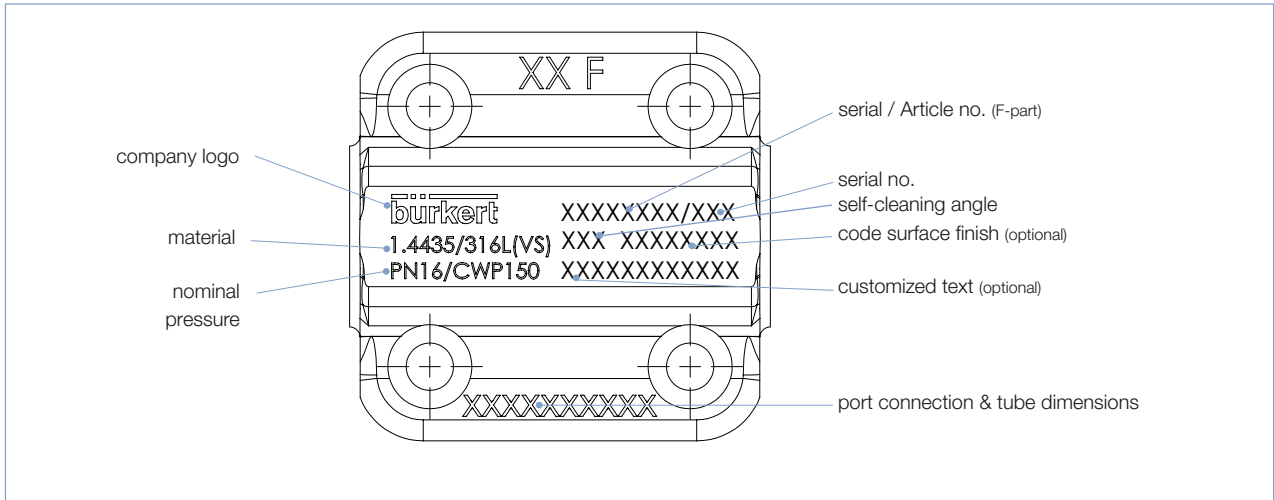

K_v values forged body

Diaphragm size	Port connection DN		K _v value forged [m ³ /h]		
	[mm]	[inch]	DIN EN ISO 1127 ISO 4200 DIN 11866 RB	DIN 11850 R2 DIN 11866 RA DIN EN 10357 RA	ASME BPE DIN11866 RC
15	15	½"	6.5	6.5	3.1
20	20	¾"	12.5	12.4	8.4
25	25	1"	18	20	15.5
40	40	1 ½"	41	40	37
50	50	2"	66	66	66

Flow rate: K_v value forged [m³/h] for elastomer membranes: Measured at +20 °C, 1 bar pressure at valve inlet and free outlet.

Ordering chart Type 2063 forged diaphragm valve

Forged body with welded connection, surface finish electropolished, $Ra \leq 0.38 \mu\text{m}$ (ASME BPE SF4), and inspection 3.1 acc. to EN-ISO 10204, further on request

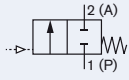
Control function	Orifice		Diaphragm size	Port connection tube \varnothing x wall thickness [mm]	K_v value water [m ³ /h]	Actuator size \varnothing [mm]	Pilot pressure [bar]	Max. operating pressure [bar]	Article no. electropolished, $Ra \leq 0.38 \mu\text{m}$, incl. 3.1 certificate
	[mm]	[inch]							
A 2/2 way valve, externally controlled, normally closed by spring operation with pilot valve (NC) 	Acc. to EN ISO 1127/ISO 4200/DIN 11866 series B								
	Diaphragm material EPDM (AD)								
	15	½"	15	21.3×1.6	6.5	50 (D)	5-10.5	8.5	285310
						70 (M)	5-10.5	10	285311
	20	¾"	20	26.9×1.6	12.5	70 (M)	5-10.5	10	285312
	25	1"	25	33.7×2.0	18	70 (M)	5-10.5	6.5	285313
						90 (N)	5.5-10.5	10	285314
	40	1 ½"	40	48.3×2.0	41	90 (N)	5.5-10.5	5.5	285315
						130 (P)	5-7.5	10	285316
	50	2"	50	60.3×2.0	66	130 (P)	5-7.5	8	285317
	Diaphragm material PTFE/EPDM (EU)								
	15	½"	15	21.3×1.6	6.5	50 (D)	5-10.5	5	285335
						70 (M)	5-10.5	10	285336
	20	¾"	20	26.9×1.6	12.5	70 (M)	5-10.5	10	285337
	25	1"	25	33.7×2.0	18	70 (M)	5-10.5	6	282091
						90 (N)	5.5-10.5	8	285338
	40	1 ½"	40	48.3×2.0	41	90 (N)	5.5-10.5	5	285339
						130 (P)	5-7.5	10	285340
	50	2"	50	60.3×2.0	66	130 (P)	5-7.5	7	285341
	Acc. to DIN 11850 series 2/DIN 11866 series A/DIN EN 10357 series B								
	Diaphragm material EPDM (AD)								
	15	½"	15	19.0×1.5	6.5	50 (D)	5-10.5	8.5	285301
						70 (M)	5-10.5	10	285302
	20	¾"	20	23.0×1.5	12.4	70 (M)	5-10.5	10	285304
	25	1"	25	29.0×1.5	20	70 (M)	5-10.5	6.5	285305
						90 (N)	5.5-10.5	10	285306
	40	1 ½"	40	41.0×1.5	40	90 (N)	5.5-10.5	5.5	285307
						130 (P)	5-7.5	10	285308
	50	2"	50	53.0×1.5	66	130 (P)	5-7.5	8	285309
	Diaphragm material PTFE/EPDM (EU)								
15	½"	15	19.0×1.5	6.5	50 (D)	5-10.5	5	285326	
					70 (M)	5-10.5	10	285327	
20	¾"	20	23.0×1.5	12.4	70 (M)	5-10.5	10	285328	
25	1"	25	29.0×1.5	20	70 (M)	5-10.5	6	285329	
					90 (N)	5.5-10.5	8	285330	
40	1 ½"	40	41.0×1.5	40	90 (N)	5.5-10.5	5	285331	
					130 (P)	5-7.5	10	285333	
50	2"	50	53.0×1.5	66	130 (P)	5-7.5	7	285334	

i Further versions on request



Material
advanced PTFE/EPDM (EU), GYLON®/EPDM laminated (ER)



Port connection
Clamp acc. to SMS3008; Tri-Clamps acc. to ASME BPE, DIN 32676 series A, ISO 2852 / SMS 3017; others on request



Control function
B (normally closed by spring action) / I (double acting)



Additional
Surface finishes, mechanically polished $Ra \leq 0.5 \mu\text{m}$ (ASME BPE SF5)
Versions with reduced spring force for higher membrane life

Ordering chart Type 2063 forged diaphragm valve, *continued*

Forged body with welded connection, surface finish electropolished, $Ra \leq 0.38 \mu\text{m}$ (ASME BPE SF4), and inspection 3.1 acc. to EN-ISO 10204, further on request

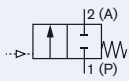
Control function	Orifice		Diaphragm size	Port connection tube \varnothing x wall thickness [mm]	K_v value water [m ³ /h]	Actuator size \varnothing [mm]	Pilot pressure [bar]	Max. operating pressure [bar]	Article no. electropolished, $Ra \leq 0.38 \mu\text{m}$, incl. 3.1 certificate
	[mm]	[inch]							
A 2/2 way valve, externally controlled, normally closed by spring operation with pilot valve (NC) 	Acc. to ASME BPE/DIN 11866 series C								
	Diaphragm material EPDM (AD)								
	15	½"	15	12.7 × 1.65	3.1	50 (D)	5-10.5	8.5	285292
						70 (M)	5-10.5	10	285294
	20	¾"	20	19.05 × 1.65	8.4	70 (M)	5-10.5	10	285295
	25	1"	25	25.4 × 1.65	15.5	70 (M)	5-10.5	6.5	285296
						90 (N)	5.5-10.5	10	285297
	40	1 ½"	40	38.1 × 1.65	37	90 (N)	5.5-10.5	5.5	285298
						130 (P)	5-7.5	10	285299
	50	2"	50	50.8 × 1.65	66	130 (P)	5-7.5	8	285300
	Diaphragm material PTFE/EPDM (EU)								
	15	½"	15	12.7 × 1.65	3.1	50 (D)	5-10.5	5	285318
						70 (M)	5-10.5	10	285319
	20	¾"	20	19.05 × 1.65	8.4	70 (M)	5-10.5	10	285320
						70 (M)	5-10.5	10	285321
	25	1"	25	25.4 × 1.65	15.5	70 (M)	5-10.5	6	285322
						90 (N)	5.5-10.5	8	285323
	40	1 ½"	40	38.1 × 1.65	37	90 (N)	5.5-10.5	5	285324
						130 (P)	5-7.5	10	285325
	50	2"	50	50.8 × 1.65	66	130 (P)	5-7.5	7	285325

Further versions on request



Material
advanced PTFE/EPDM (EU), GYLON®/EPDM laminated (ER)



Port connection
Clamp acc. to SMS3008; Tri-Clamps acc. to ASME BPE, DIN 32676 series A, ISO 2852 / SMS 3017; others on request



Control function
B (normally closed by spring action) / I (double acting)



Additional
Surface finishes, mechanically polished $Ra \leq 0.5 \mu\text{m}$ (ASME BPE SF5)
Versions with reduced spring force for higher membrane life

Cast

K_v value cast body

Diaphragm size	Actuator size DN		K _v value [m ³ /h]
	[mm]	[inch]	
15	15	½"	5.5
20	20	¾"	10
25	25	1"	14
40	40	1 ½"	30
50	50	2"	51.5

Flow rate: K_v value forged [m³/h] for elastomer membranes: Measured at +20 °C, 1 bar pressure at valve inlet and free outlet.

Ordering chart Type 2063 cast version

Cast body with welded connection, surface finish mechanically polished, Ra ≤ 0.8 µm, others on request

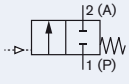
Control function	Orifice		Diaphragm size	Port connection tube Ø x wall thickness [mm]	K _v value water [m³/h]	Actuator size Ø [mm]	Pilot pressure [bar]	Max. operating pressure [bar]	Article no. mechanically polished, Ra ≤ 0.8 µm
	[mm]	[inch]							
A 2/2 way valve, externally controlled, normally closed by spring operation with pilot valve (NC) 	Acc. to EN ISO 1127/ISO 4200/DIN 11866 series B								
	Diaphragm material EPDM (AD)								
	15	½"	15	21.3 × 1.6	5.5	50 (D)	5-10.5	8.5	285259
						70 (M)	5-10.5	10	285260
	20	¾"	20	26.9 × 1.6	10.0	70 (M)	5-10.5	10	285262
	25	1"	25	33.7 × 2.0	14.0	70 (M)	5-10.5	6.5	285263
						90 (N)	5.5-10.5	10	285264
	40	1 ½"	40	48.3 × 2.0	30.0	90 (N)	5.5-10.5	5.5	285267
						130 (P)	5-7.5	10	285268
	50	2"	50	60.3 × 2.0	51.5	130 (P)	5-7.5	8	285269
	Diaphragm material PTFE/EPDM (EA)								
	15	½"	15	21.3 × 1.6	5.5	50 (D)	5-10.5	5	285284
						70 (M)	5-10.5	10	285285
	20	¾"	20	26.9 × 1.6	10.0	70 (M)	5-10.5	10	285286
	25	1"	25	33.7 × 2.0	14.0	70 (M)	5-10.5	6	285287
						90 (N)	5.5-10.5	8	285288
	40	1 ½"	40	48.3 × 2.0	30.0	90 (N)	5.5-10.5	5	285289
						130 (P)	5-7.5	10	285290
	50	2"	50	60.3 × 2.0	51.5	130 (P)	5-7.5	7	285291
	Acc. to DIN 11850 series 2/DIN 11866 series A/DIN EN 10357 series B								
	Diaphragm material EPDM (AD)								
	15	½"	15	19.0 × 1.5	5.5	50 (D)	5-10.5	8.5	285250
						70 (M)	5-10.5	10	285252
	20	¾"	20	23.0 × 1.5	10.0	70 (M)	5-10.5	10	285253
	25	1"	25	29.0 × 1.5	14.0	70 (M)	5-10.5	6.5	285254
						90 (N)	5.5-10.5	10	285255
	40	1 ½"	40	41.0 × 1.5	30.0	90 (N)	5.5-10.5	5.5	285256
						130 (P)	5-7.5	10	285257
	50	2"	50	53.0 × 1.5	51.5	130 (P)	5-7.5	8	285258
	Diaphragm material PTFE/EPDM (EA)								
	15	½"	15	19.0 × 1.5	5.5	50 (D)	5-10.5	5	285276
						70 (M)	5-10.5	10	285277
	20	¾"	20	23.0 × 1.5	10.0	70 (M)	5-10.5	10	285278
	25	1"	25	29.0 × 1.5	14.0	70 (M)	5-10.5	6	285279
						90 (N)	5.5-10.5	8	285280
	40	1 ½"	40	41.0 × 1.5	30.0	90 (N)	5.5-10.5	5	285281
					130 (P)	5-7.5	10	285282	
50	2"	50	53.0 × 1.5	51.5	130 (P)	5-7.5	7	285283	

i Further versions on request



Material
advanced PTFE/EPDM (EU), GYLON®/EPDM laminated (ER)



Port connection
Clamp acc. to SMS3008; Tri-Clamps acc. to ASME BPE, DIN 32676 series A, ISO 2852 / SMS 3017; others on request



Control function
B (normally closed by spring action) / I (double acting)



Additional
Surface finishes electropolished Ra ≤ 0.6 µm (ASME BPE SF6)

Ordering chart Type 2063 cast version

Cast body with welded connection, surface finish mechanically polished, $Ra \leq 0.8 \mu\text{m}$, others on request

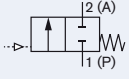
Control function	Orifice		Diaphragm size	Port connection tube \varnothing x wall thickness [mm]	K_v value water [m^3/h]	Actuator size \varnothing [mm]	Pilot pressure [bar]	Max. operating pressure [bar]	Article no. mechanically polished, $Ra \leq 0.8 \mu\text{m}$
	[mm]	[inch]							
A 2/2 way valve, externally controlled, normally closed by spring operation with pilot valve (NC) 	Acc. to ASME BPE/DIN 11866 series C								
	Diaphragm material EPDM (AD)								
	20	3/4"	20	19.05 x 1.65	10.0	70 (M)	5 - 10.5	10	285243
	25	1"	25	25.4 x 1.65	14.0	70 (M)	5 - 10.5	6.5	285244
						90 (N)	5.5 - 10.5	10	285246
	40	1 1/2"	40	38.1 x 1.65	30.0	90 (N)	5.5 - 10.5	5.5	285247
						130 (P)	5 - 7.5	10	285248
	50	2"	50	50.8 x 1.65	51.5	130 (P)	5 - 7.5	8	285249
	Diaphragm material PTFE/EPDM (EA)								
	20	3/4"	20	19.05 x 1.65	10.0	70 (M)	5 - 10.5	10	285270
	25	1"	25	25.4 x 1.65	14.0	70 (M)	5 - 10.5	6	285271
						90 (N)	5.5 - 10.5	8	285272
	40	1 1/2"	40	38.1 x 1.65	30.0	90 (N)	5.5 - 10.5	5	285273
						130 (P)	5 - 7.5	10	285274
	50	2"	50	50.8 x 1.65	51.5	130 (P)	5 - 7.5	7	285275

Further versions on request

**Material**

advanced PTFE/EPDM (EU), GYLONR/EPDM laminated (ER)

**Port connection**

Clamp acc. to SMS3008; Tri-Clamps acc. to ASME BPE, DIN 32676 series A, ISO 2852 / SMS 3017; others on request

**Control function**

B (normally closed by spring action) / I (double acting)

**Additional**Surface finishes electropolished $Ra \leq 0.6 \mu\text{m}$ (ASME BPE SF6)

Dimensions Type 2063 forged and cast diaphragm valve [mm]

Forged

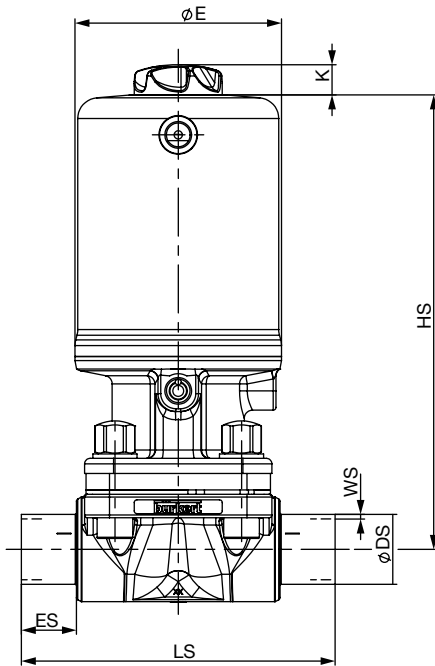

All bodies							acc. to EN ISO 1127/ISO 4200/DIN 11866 series B				acc. to ASME BPE/DIN 11866 series C			
Orifice		Diaphragm size	Actuator size	ØE [mm]	K [mm]	HS [mm]	LS [mm]	ES [mm]	ØDS [mm]	WS [mm]	LS [mm]	ES [mm]	ØDS [mm]	WS [mm]
[mm]	[inch]													
15	½"	15	50 (D)	55	26.5	131	110	30.8	21.3	1.6	108	29.8	12.7	1.65
			70 (M)	75	26.5	139.4								
20	¾"	20	70 (M)	75	26.5	154.3	119	29.6	26.9	1.6	117	28.3	19.05	1.65
25	1"	25	70 (M)	75	26.5	165.1	129	20	33.7	2	114	20	25.4	1.65
			90 (N)	96	29	187								
40	1 ½"	40	90 (N)	96	29	206.5	161	20	48.3	2	159	34.5	38.1	1.65
			130 (P)	137	29	258.9								
50	2"	50	130 (P)	137	29	272.7	192	20	76.1	2.3	190	41	63.5	1.65

All bodies							acc. to DIN 11850 series 2/DIN 11866 series A/DIN EN 10357 series B			
Orifice		Diaphragm size	Actuator size	ØE [mm]	K [mm]	HS [mm]	LS [mm]	ES [mm]	ØDS [mm]	WS [mm]
[mm]	[inch]									
15	½"	15	50 (D)	55	26.5	131	110	30.8	19	1.5
			70 (M)	75	26.5	139.4				
20	¾"	20	70 (M)	75	26.5	154.3	119	20	23	1.5
25	1"	25	70 (M)	75	26.5	165.1	129	20	29	1.5
			90 (N)	96	29	187				
40	1 ½"	40	90 (N)	96	29	206.5	161	20	41	1.5
			130 (P)	137	29	258.9				
50	2"	50	130 (P)	137	29	272.7	192	42	70	2

Ordering information for valve system On/Off with stainless steel actuator Type 8801-DV

An On/Off valve system with stainless steel actuator, Type 8801-DV, consists of a diaphragm valve, Type 2063 and position feedback Type 8697 (see separate datasheets; 8801 DV with 8697 feedback function)

Diaphragm valve Type 2063 welded connection



Feedback

Type 8697



Valve System On/Off



Type 8801-DV
2063 + 8697

Electrical position feedback

More
info.



Type 8697

Actuator size 50 to 130

The pneumatic control unit Type 8697 is designed for integrated mounting on CLASSIC series 20XX process valves suiting the requirements of hygienic process environment mechanical or inductive limit switches register the position of the valve.

Features











- Compact design
- LED position indicator
- Mechanical or inductive limit switches for end position registering
- Easy to clean chemically resistant housing featuring IP65 / IP67, 4X Rating
- Optional intrinsically safe version acc. to ATEX

Benefits

- Easy and quick installation
- High level of signal reliability thanks to self adjusting limit switches
- Signal safety through the automatic adjustment of the limit switches
- Minimised space requirement in the plant piping for more flexibility in plant design

Ordering chart accessories

Note: Accessories has to be ordered separately

Accessory	for actuator size	Article no.
Stainless steel silencer set (VA-Silencer incl. PTFE sealing ring)	universal	696931 
Max. stroke limitation	D (Ø50), M (Ø70)	699550 
	N (Ø90), P (Ø130)	699994 
Min.-/Max. stroke limitation	D (Ø50), M (Ø70)	699986 
	N (Ø90), P (Ø130)	699998 
Proximity switch (single)	D (Ø50), M (Ø70)	699989 
	N (Ø90), P (Ø130)	699991 
Proximity switch (double)	D (Ø50), M (Ø70)	699990 
	N (Ø90), P (Ø130)	699992 
Adaptionsset 8697*	D (Ø50), M (Ø70)	699551 
	N (Ø90), P (Ø130)	580000 
8697*	universal	depending on version

For further accessories see accessories datasheet Type 2XXX for the full options programme.



Valve features, specification key - Request for quotation

Example

2063 A 15 AD VS SA42 NK52 + NO23

Specification key

2063 [] [] [] [] [] [] [] +

(Please make a choice)

CONTROL FUNCTION	
A	normally closed by spring action
B	normally open by spring action
I	double acting

ORIFICE [mm] (diaphragm)	
08	
10	
15	
20	
25	
32	
40	
50	

SEAL MATERIAL	
AD	EPDM
EA	PTFE/EPDM
ER	GYLON®/EPDM laminated
EU	advanced PTFE/EPDM in two pieces

BODY MATERIAL	
VG	Stainless steel, cast 316L / 1.4435
VS	Forged stainless steel 316L/1.4435/BN2
VP	Tube formed bodies

VARIABLE CODES	
Surfaces - forged design	
NO14	Int. Mechanically polished Ra ≤ 0.5 µm (ASME BPE SF1)
NO17	Int. Electro polished Ra ≤ 0.38 µm (ASME BPE SF4)
Surfaces - cast version	
NO06	Int. Mechanically polished Ra ≤ 0.76 µm (ASME BPE SF3)
NO16	Int. Electro polished Ra ≤ 0.6 µm (ASME BPE SF6)
EC04	Reduced spring force

CERTIFICATE	
NK52	3.1 Approval

Standard	
NO06	Int. Mechanically polished Ra ≤ 0.76 µm (ASME BPE SF3)
NO17	Int. Electro polished Ra ≤ 0.38 µm (ASME BPE SF4)



DN [mm]	Port connection weld end							
	EN ISO 1127/ ISO 4200 DIN 11866 S. B	SMS 3008	DIN 11850 S. 0	DIN 11850 R. 1	DIN 11850 S. 2 DIN 11866 S. A	DIN 11850 R. 3	BS4825	ASME BPE DIN 11866 S. C
8	SA40 - 13.5 × 1.6		SC42 - 10.0 × 1.0				SODB - 6.35 × 1.2	SA90 - 6.35 × 0.89
10	SA41 - 17.2 × 1.6			SF40 - 12.0 × 1.0	SD40 - 13.0 × 1.5	SE40 - 14.0 × 2.0	SODC - 9.53 × 1.2	SA91 - 9.53 × 0.89
15	SA42 - 21.3 × 1.6	SA58 - 12.0 × 1.0	SC43 - 18.0 × 1.5	SF41 - 18.0 × 1.0	SD42 - 19.0 × 1.5	SE42 - 20.0 × 2.0	SODD - 12.7 × 1.2	SA92 - 12.7 × 1.65
20	SA43 - 26.9 × 1.6	SA59 - 18.0 × 1.0	SC44 - 22.0 × 1.5	SF42 - 22.0 × 1.0	SD43 - 23.0 × 1.5	SE43 - 24.0 × 2.0	SODE - 19.05 × 1.2	SA93 - 19.05 × 1.65
25	SA44 - 33.7 × 2.0	SA60 - 25.0 × 1.2	SC45 - 28.0 × 1.5	SF43 - 28.0 × 1.0	SD44 - 29.0 × 1.5	SE44 - 30.0 × 2.0		SODF - 25.4 × 1.65
32	SA45 - 42.4 × 2.0	SA61 - 33.7 × 1.2	SC46 - 34.0 × 1.5	SF44 - 34.0 × 1.0	SD45 - 35.0 × 1.5	SE45 - 36.0 × 2.0		
40	SA46 - 48.3 × 2.0	SA62 - 38.0 × 1.2	SC47 - 40.0 × 1.5	SF45 - 40.0 × 1.0	SD46 - 41.0 × 1.5	SE46 - 42.0 × 2.0		SODH - 38.1 × 1.65
50	SA47 - 60.3 × 2.0	SA63 - 51.0 × 1.2	SC48 - 52.0 × 1.5	SF46 - 52.0 × 1.0	SD47 - 53.0 × 1.5	SE47 - 54.0 × 2.0		SODI - 50.8 × 1.65

DN [mm]	Port connection Clamp				
	Clamp 34.0 like DIN 32676 S. B (ISO-tube (ISO4200))	DIN 32676 S. A (DIN-tube (DIN11850))	DIN 32676 S. B (ISO-tube (ISO4200))	ASME BPE	BS 4825 (Clamp BS 4825 - 3, tube BS 4825 - 1)
8	TC51 - 13.5 × 1.6 Ci: 34.0	TD40 - 10.0 × 1.0 Ci: 25.0	TC40 - 13.5 × 1.6 Ci: 25.0	TG50 - 6.35 × 0.89 Ci: 25.0	
10	TC41 - 17.2 × 1.6 Ci: 34.0	TD41 - 13.0 × 1.5 Ci: 34.0	TC53 - 17.2 × 1.6 Ci: 25.0	TG01 - 9.53 × 0.89 Ci: 25.0	
15	TC42 - 21.3 × 1.6 Ci: 34.0	TD42 - 19.0 × 1.5 Ci: 34.0	TC52 - 21.3 × 1.6 Ci: 50.5	TG02 - 12.7 × 1.65 Ci: 25.0	TH42 - 12.7 × 1.2 Ci: 25.0
20		TD43 - 23.0 × 1.5 Ci: 34.0	TC43 - 26.9 × 1.6 Ci: 50.5	TG03 - 19.05 × 1.65 Ci: 25.0	TH43 - 19.05 × 1.2 Ci: 25.0
25		TD44 - 29.0 × 1.5 Ci: 50.5	TC44 - 33.7 × 2.0 Ci: 50.5	TG04 - 25.4 × 1.65 Ci: 50.5	
32					
40		TD46 - 41.0 × 1.5 Ci: 50.5	TC46 - 48.3 × 2.0 Ci: 64.0	TG05 - 38.1 × 1.65 Ci: 50.5	
50		TD47 - 53.0 × 1.5 Ci: 64.0	TC47 - 60.3 × 2.0 Ci: 77.5	TG06 - 50.8 × 1.65 Ci: 64.0	

Valve system On/Off with stainless steel actuator Type 8801-DV – request for quotation

Please fill out and send to your nearest Bürkert facility* with your inquiry or order

Company	Contact person
Customer no.	Department
Address	Tel./Fax
Postcode/town	E-Mail

= mandatory fields to fill out

Quantity

Required delivery date

Operating data

Pipe line	DN <input type="text"/>	PN <input type="text"/>
Pipe material	<input type="text"/>	
Process medium	<input type="text"/>	
Type of media	<input type="checkbox"/> Liquid	<input type="checkbox"/> Steam <input type="checkbox"/> Gas

Valve features

Specification key

2063

(automatically transferred from p. 15)

Surface finish (if not standard) internal µm external µm

Pilot pressure min. max.

ATEX II 2GD Mechanical

Automation unit features

Click on the orange box "More info"... you will come to our website for the resp. product where you can download the data sheet.

Electrical Feedback

Type 8697

For actuator size 50 to 130

More info.



- LED-position indicator
- Micro- or proximity switches for end position feedback
- Gehäuse nach IP65/67, 4X Rating
- Optional intrinsically safe version acc. to ATEX / IECEx

Position feedback switches

- Micro-switch 24 V DC
- Micro-switch 50 – 225 V DC/AC
- Inductive switch 3-wire PNP
- Inductive switch 2-wire NAMUR
- Inductive switch 2-wire 24 V DC

Electrical connection

- Cable gland
- M12 plug
- (only with inductive switch 3-wire PNP)

No. of Position feedback switches

2x

Approvals

- ATEX cat. 3GD, IECEx
- ATEX cat. 2DG, IECEx
- without

Valve system On/Off with stainless steel actuator Type 8801-DV , *continued*

Certifications

- Certificate of compliance with the order EN-ISO 10204 2.1 (Article no. 440788)
- Test report 2.2 2.2 EN-ISO 10204 (Article no. 803722)
- Test certificate 3.1 according to EN-ISO 10204 (included with forged housing version)
- Certification of conformity for surface quality DIN 4762-DIN 4768-ISO / 4287/1 (Article no. 804175)
- Certification of conformity for pickling and electro polish processes (Article no. 444900)
- Food & Beverage (according to EC Directive 1935/2004 / EC)
- Certification according to FDA and USP

Comment /sketch

DTS 1000291829 EN Version: D Status: RL (released | freigegeben | validé) printed: 30.01.2018

To find your nearest Bürkert facility, click on the orange box → www.burkert.com

In case of special application conditions,
please consult for advice.

Subject to alteration.
© Christian Bürkert GmbH & Co. KG

1801/3_EU-en_00895316